

INSTRUCTION MANUAL

Serial Number _____

TYPE 291

Tektronix, Inc.

S.W. Millikan Way ● P. O. Box 500 ● Beaverton, Oregon ● Phone MI 4-0161 ● Cables: Tektronix

Tektronix International A.G.

Terrassenweg 1A ● Zug, Switzerland ● PH. 042-49192 ● Cable: Tekintag, Zug Switzerland ● Telex 53.574



WARRANTY

All Tektronix instruments are warranted against defective materials and workmanship for one year. Tektronix transformers, manufactured in our own plant, are warranted for the life of the instrument.

Any questions with respect to the warranty mentioned above should be taken up with your Tektronix Field Engineer.

Tektronix repair and replacement-part service is geared directly to the field, therefore all requests for repairs and replacement parts should be directed to the Tektronix Field Office or Representative in your area. This procedure will assure you the fastest possible service. Please include the instrument Type and Serial number with all requests for parts or service.

Specifications and price change privileges reserved.

Copyright © 1963 by Tektronix, Inc., Beaverton, Oregon. Printed in the United States of America. All rights reserved. Contents of this publication may not be reproduced in any form without permission of the copyright owner.



CONTENTS

Warranty

- Section 1 Characteristics
- Section 2 Diode Switching
- Section 3 Operating Instructions
- Section 4 Circuit Description
- Section 5 Maintenance
- Section 6 Check Adjustment
- Section 7 Parts List and Schematics

TYPE 291 DIODE SWITCHING TIME TESTER POWER SUPPLY

SERIAL

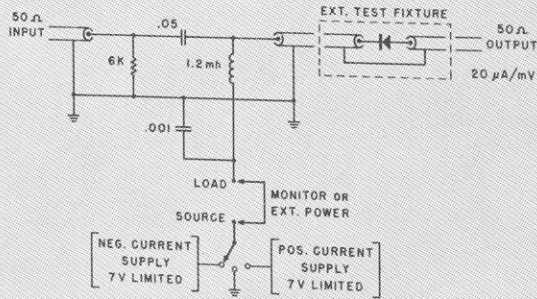

POWER/POLARITY
AT CATHODE
OFF

NEG.

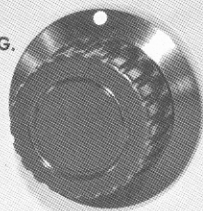

POS.

CURRENT
VARIABLE



CURRENT
m AMPS

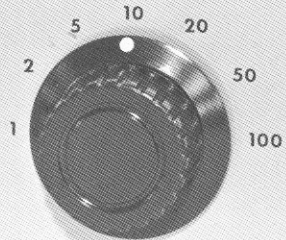

TEKTRONIX, INC., PORTLAND, OREGON, U.S.A.

SECTION 1

CHARACTERISTICS

General Information

The Tektronix Type 291 Diode Switching Time Tester Power Supply is designed to be used with a pulse generator and either a sampling or real-time oscilloscope for measuring switching characteristics of fast-switching diodes.

The Type 291 with its associated equipment provides a versatile system for accurately measuring stored charges as small as 0.1 picocoulomb and recovery time down to $\frac{1}{3}$ nsec.

Input Pulse Requirements

See "Pulse Generator and Oscilloscope Requirements" in section 3.

Impedance Requirements

See "Pulse Generator and Oscilloscope Requirements" in section 3.

Diode-Recovery Loop Impedance

100 ohms.

Risetime Response

Better than 0.35 nanosecond.

Power Supply Current

Seven ranges of current continuously adjustable from about 1 microamp to 100 milliamps. Calibrated at 1, 2, 5, 10, 20, 50, and 100 milliamps. Calibration accuracy at 100 milliamps, $\pm 3\%$; all other, $\pm 2\%$.

Power Requirements

105-125 or 210-250 volts, 50-400 cycles, 6 watts.

Mechanical

Construction—Die-cast aluminum-alloy top and bottom covers with steel wrap-around housing. Aluminum alloy power chassis.

Finish—Photo-etched anodized-aluminum front panel, blue vinyl paint over steel wrap-around housing.

Weight—Approximately 4 pounds 11 ounces.

Overall Dimensions— $4\frac{1}{16}$ inches high, $6\frac{9}{16}$ inches wide, $8\frac{1}{8}$ inches long.

SECTION 2

DIODE SWITCHING

Introduction

The following is a general explanation of what happens in a diode when a forward or reverse voltage is applied.

Forward Recovery

Forward Recovery occurs when a diode with no voltage applied is suddenly turned "on" with a forward voltage. The forward voltage switches the diode current from zero to some forward equilibrium value in a certain time. The current switches because the forward voltage produces an electric field across the diode that forces carriers (electrons and holes) to move toward the PN junction.

Before switching, with zero current and no applied electric field, there are a few holes in the N material and a few electrons in the P material near the PN junction (see Fig. 2-1, zero bias).

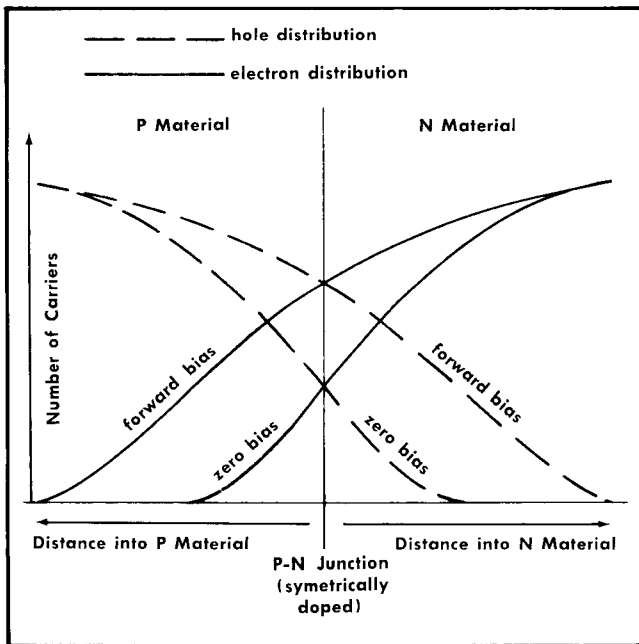

Fig. 2-1. Electron and hole distribution at PN junction.

When the forward voltage is applied, the electric field moves more carriers across the PN junction. Some of the carriers already across are moved even further (see Fig. 2-1, forward bias). The carriers crossing the PN junction are replaced by electrons and holes sweeping toward the junction (as two masses) from the ohmic connections as shown in Fig. 2-2. When the carriers in these masses leave the ohmic connections, each is replaced by a carrier from the switching voltage source, thus starting forward diode current.

Continuous forward diode current is produced by holes combining with electrons in the region of the PN junction. When a hole combines with an electron, both are lost as carriers, but other carriers move from the ohmic connections to replace those lost, thus producing diode current. The amount of diode current depends on how far the carriers are forced across the junction by the applied electric field. (Increasing the forward voltage increases the electric field strength.)

For each value of forward voltage there is a corresponding value of forward equilibrium (steady state) diode current. At equilibrium, the rate that carriers enter the ohmic connections equals the rate that carriers are lost in the region of the PN junction.

Fig. 2-3 shows diode current changes that occur from the time forward voltage is applied until forward equilibrium current is reached.

Reverse Recovery

Reverse recovery occurs when a diode with forward current suddenly has a reverse voltage applied to it. The reverse voltage generates a proportional reverse electric field that switches the diode current from a forward value, through zero, to a reverse value, then back to zero.

With forward diode current (forward voltage applied) some carriers pass through the PN junction and travel a considerable distance before they combine. Therefore, there are holes in the N material and electrons in the P material (see Fig. 2-4, forward bias). These electrons and

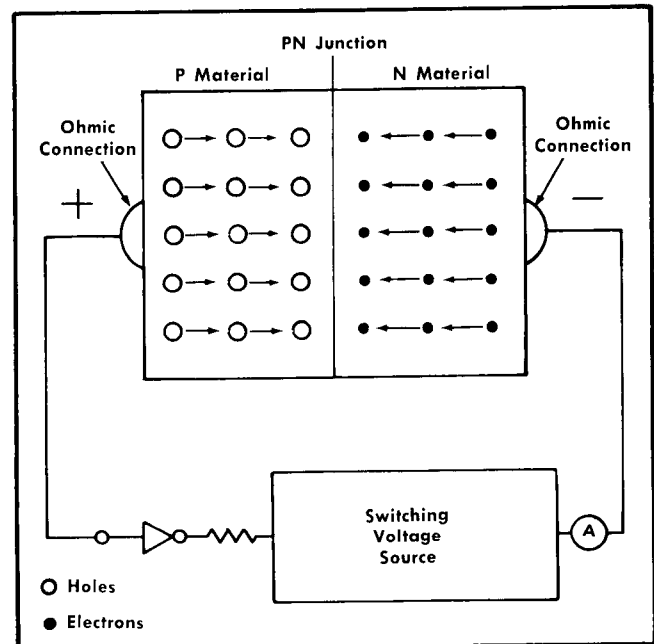

Fig. 2-2. PN diode with forward switching voltage applied.

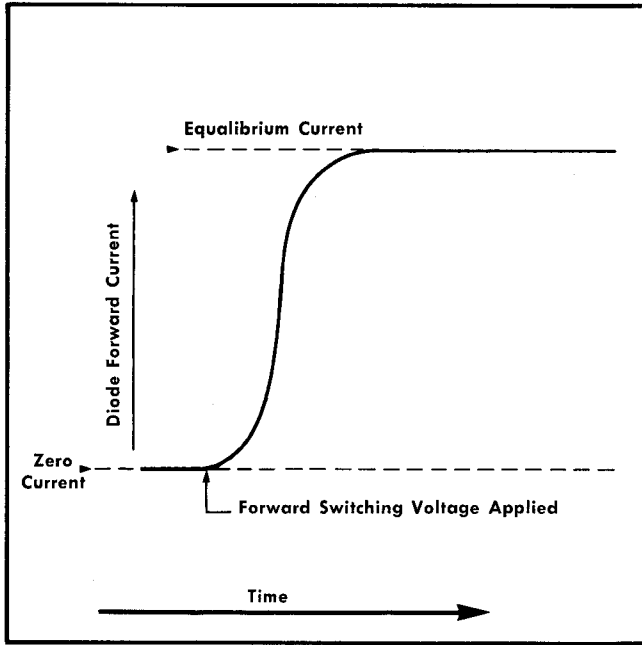

Fig. 2-3. Diode forward recovery current.

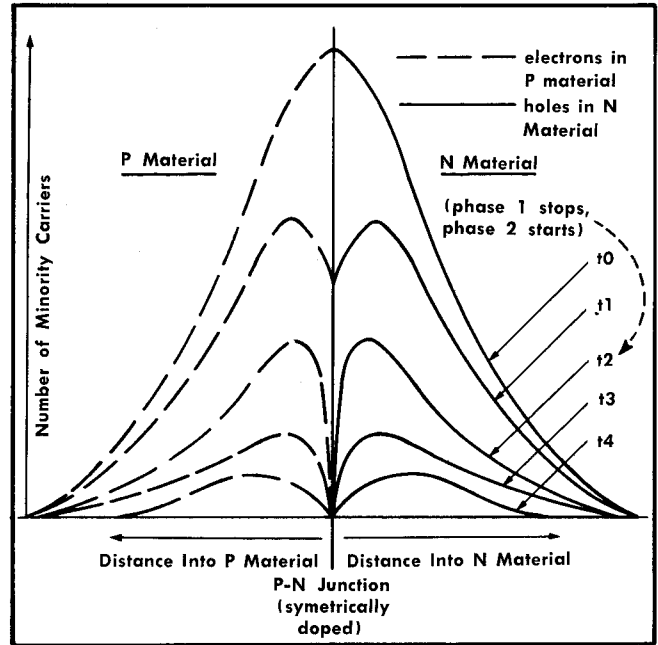

Fig. 2-5. Minority carrier (stored charge) distribution around forward biased PN junction.

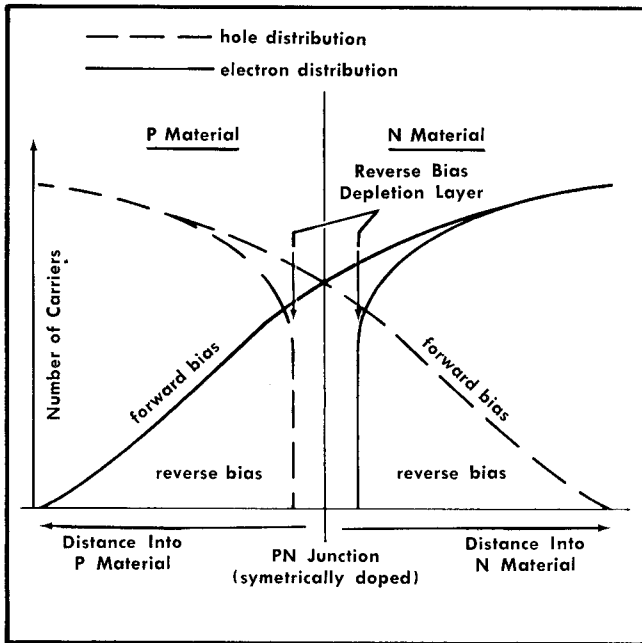

Fig. 2-4. Electron and hole distribution at PN junction.

holes form a stored charge that is distributed around the PN junction (see Fig. 2-5, t_0). The forward voltage determines the distance carriers travel past the junction, and the number that pass through the junction. Thus, the amount of stored charge is proportional to the forward voltage applied.

When reverse voltage is applied, the reverse electric field forces electrons toward the N material ohmic connection, and holes toward the P material ohmic connection. The carriers entering the external circuit from the ohmic connections produce the reverse diode current.

The maximum value of this reverse diode current depends on the maximum rate that carriers move toward the ohmic connections. Carriers moving toward the ohmic connections deplete the stored charge first, then form a reverse-bias depletion layer at the PN junction as shown in Fig. 2-4.

Usually, most of the reverse diode current is supplied by the carriers in the stored charge, however, some current is supplied during the formation of the depletion layer. The stored charge is depleted (in sequence indicated by t_0, t_1, t_2, t_3 and t_4 in Fig. 2-5) as holes and electrons are pulled across the PN junction toward the ohmic connections. After the stored charge is depleted, the depletion layer is formed as the holes and electrons are pulled farther from the PN junction. The size of the stored charge and the size of the depletion layer determines the number of carriers available for reverse diode current. However, the size of the stored charge has the greater effect. The reverse diode current stops when the carriers are pulled back the maximum distance from the junction by the reverse electric field. The maximum distance the carriers are pulled back from the junction (size of layer) is proportional to the value of the reverse switching voltage applied.

Not all of the carriers available for reverse diode current reach the external circuit to produce current. Some of the electrons and holes combine and are lost as carriers before they reach the ohmic connections. Usually the

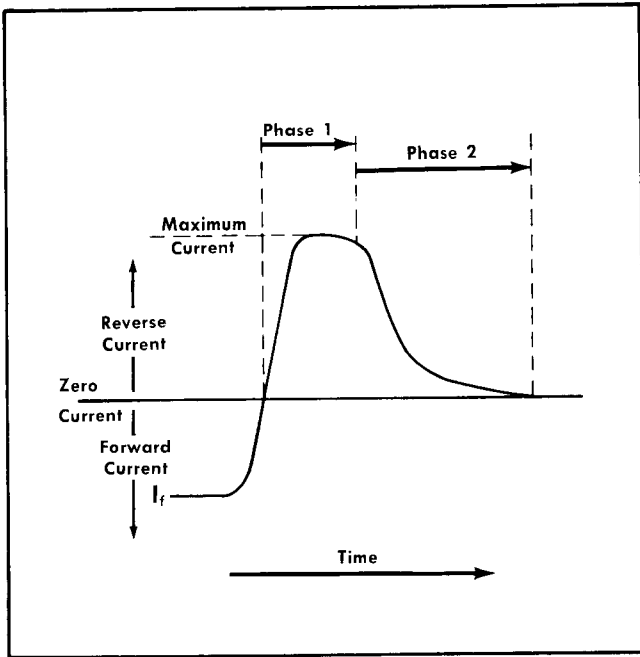

Fig. 2-6. Diode reverse recovery current.

number of these depends on the time available for them to combine after the reverse switching voltage is applied. The time available for combination can be reduced by increasing the reverse switching voltage applied, which increase the rate carriers are removed from the diode.

During reverse recovery, the diode reverse current changes as shown in Fig. 2-6. These changes result from the changes in the rate at which carriers leave the ohmic connections. During the time t_0 to t_2 (Fig. 2-5), when there are electrons and holes at the PN junction, the rate at which carriers leave the ohmic connections is greatest. Thus, the initial diode reverse current is maximum as shown in Fig. 2-5 (phase 1). After most of the carriers are depleted at the PN junction (time t_2 in Fig. 2-5), and until the depletion layer is completely formed, the rate carriers leave the ohmic connections reduces to zero. Therefore, the diode reverse current reduces to zero (disregarding leakage current) as shown in Fig. 2-6 (phase 2).

During reverse recovery, changes in reverse diode current depend on both the diode and the voltages applied. The value of forward voltage applied before the diode is switched determines the size of the stored charge (number of available carriers). The size of the reverse voltage determines the maximum diode current, the number of available carriers recovered as reversed diode current, and the size of the reverse bias depletion layer.

SECTION 3

OPERATING INSTRUCTIONS

Introduction

This section contains operating information for the Type 291 and associated equipment. However, before operating the instrument, the operator should be familiar with the information under "Preliminary Considerations".

PRELIMINARY CONSIDERATIONS

Power Requirements

The Type 291 Power Supply is factory wired for 117-volt operation, but can be wired for 234-volt operation. It will operate properly between 105 and 125 volts when wired for 117-volt operation, and between 210 and 250 volts when wired for 234-volt operation.

There are two primary windings in the power transformer. One winding has its terminals marked 1 and 3; the other marked 2 and 4. For 117-volt operation, the two windings are connected in parallel by wiring terminal 1 to 2, and terminal 3 to 4. For 234-volt operation, the two windings are connected in series by wiring terminal 2 to 3. For both 117- and 234-volt operation, one ac power input lead is connected to terminal 1, and the other to terminal 4.

Fuse Requirements

Use a 1/10-amp slow-blowing type fuse when the Type 291 is wired for 117-volt operation, and a 1/16-amp slow-blowing type fuse when wired for 234-volt operation.

Pulse Generator and Oscilloscope Requirements

The pulse generator should have a 50-ohm output impedance, and provide a fast-rise pulse for diode switching. Pulse risetime should be less than the diode recovery time. The pulse duration should be longer than the diode reverse recovery time.

The pulse amplitude should be sufficient to satisfy either the switching voltage (E_{gen}) or maximum reverse current requirements. The pulse should not exceed half the diode breakdown voltage to avoid damage from the voltage-doubling effect caused when the generator is unloaded as the diode recovers. Pulse repetition rate should be slow enough for the diode to recover between pulses.

The oscilloscope used should have a 50-ohm input impedance, and be able to display risetime fast enough to measure the switching characteristics of the diode under test.

Diode Current Sources

The Type 291 constant-current circuit can furnish up to 100 milliamps at the SOURCE jack. This current is normally

applied to the test circuit by connecting the SOURCE jack to the LOAD jack.

An external constant-current supply may also be used to provide current to the test circuit through the LOAD jack. However, the current should not exceed 500 milliamps.

To monitor the test-circuit current, connect a milliammeter between the current source and the LOAD jack. The meter will indicate diode current between switching pulses. (The meter is electrically isolated from the switching pulses.)

Diode Switching Terms (See Figs. 3-1 and 3-2.)

Forward Turn-On Current (I_f)—Maximum (equilibrium) value to which the forward current rises after the diode is switched with a forward switching voltage.

Forward Turn-On Time (t_{tr})—Time it takes the diode forward current to rise from 10% to 90% of the Forward Turn-On Current (I_f) after the diode is switched with a forward switching voltage.

Forward Current (I_f)—Amount of forward current (steady state) passing through the diode before a reverse switching voltage is applied.

Reverse-Recovery Current (i_{rr})—Specified amount of reverse current to which a diode recovers when measuring Reverse Recovery Time (t_{rr}).

Reverse-Recovery Time (t_{rr})—Time interval measured from the time a reverse switching voltage is applied and the diode current reverses (zero current level) to the time the falling diode current reaches the Reverse Recovery Current (i_{rr}) level.

Stored Charge (Q_s)—Amount of charge stored by the diode, and recovered during reverse recovery. Represented by shaded area in Fig. 3-2, and usually stated in coulombs.

Tau-Sub-Que (τ_q)—Amount of charge stored by the diode, and recovered during reverse recovery for each unit of forward current ($\frac{Q_s}{I_f}$). τ_q (usually expressed in picocoulombs per milliampere) is a convenient figure of merit for comparing possible recovery time in switching diodes.

Final Recovery Voltage (V_r)—Final recovery voltage across diode when measuring reverse-recovery characteristics. When given as volts in a 100-ohm loop ($R_L = 100$ ohms), use the following formula to find generator voltage into a 40-50-ohm lead (E_{gen}).

Generator Voltage Into 50-Ohm Load (E_{gen})—Generator voltage used to test diode. When V_r is given for reverse-recovery, such as volts in a 100-ohm loop ($R_L = 100$ ohms), approximate E_{gen} can be determined by:

$$E_{gen} \cong \frac{V_r + (Z_L I_f)}{2} \text{ where } Z_L = \frac{R_L}{2} .$$

Operating Instructions — Type 291

For Type 291: $R_L = 100$ ohms.

For example: if $V_r = 6$ volts, $I_f = 10$ ma, and $R_L = 100$

ohms, then $E_{gen} \cong \frac{6 + (50 \times 0.1)}{2} = 3.25$ volts.

Forward-Switching Voltage—A negative voltage applied to the diode cathode, or a positive voltage applied to the anode.

Reverse-Switching Voltage—A negative voltage applied to the diode anode, or a positive voltage applied to the cathode.

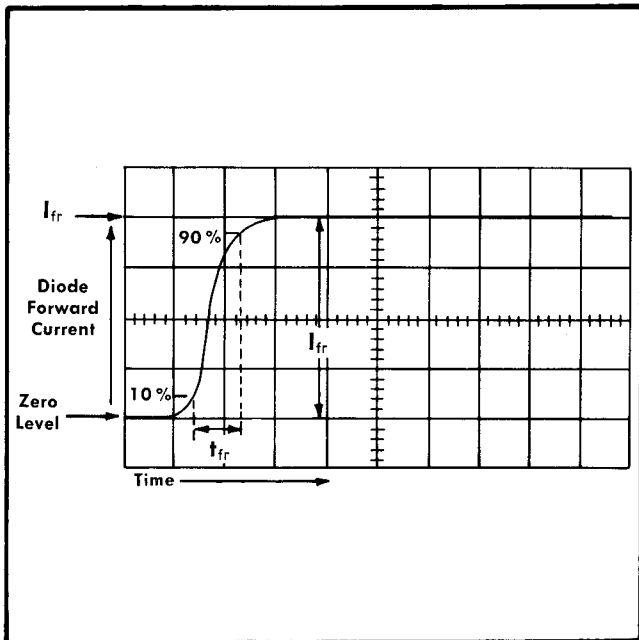

Fig. 3-1. Diode forward recovery switching display.

Function of Controls and Connectors

INPUT 50Ω Connector—Connects the fast-rise pulse generator output to the test circuit.

OUTPUT 50Ω Connector—Connects the test circuit output to the oscilloscope.

MONITOR OR EXTERNAL PWR. (LOAD and SOURCE) Jacks—The SOURCE jack is connected to the constant-current circuit output when the POWER/POLARITY switch is at either NEG. or POS. The SOURCE jack is connected to ground when the POWER/POLARITY switch is set to OFF. The LOAD jack provides a connection for applying current to the test circuit.

Shorting Plug—A shorting bar with two banana jacks. Used to connect the SOURCE jack to the LOAD jack.

POWER/POLARITY Switch—Turns instrument power on and off, and selects either a negative or positive current polarity at the SOURCE jack.

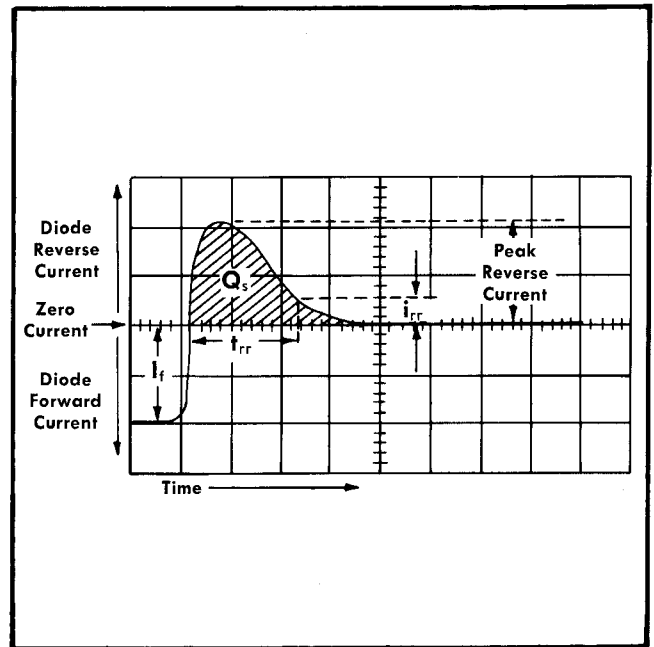

Fig. 3-2. Diode reverse recovery switching display.

CURRENT mAMPS Switch—Provides seven current values at the SOURCE jack.

CURRENT VARIABLE Control—In the CALIB. position, the current at the SOURCE jack is calibrated to equal the setting of the CURRENT mAMPS switch. This control also varies the current at the SOURCE jack from about zero to the value indicated on the CURRENT mAMPS control.

MEASURING TECHNIQUES

The following is a discussion of techniques for measuring forward- and reverse-recovery switching characteristics of a diode. Forward recovery occurs when a diode switches from zero current to some forward current value when a forward-switching pulse is applied. Reverse recovery occurs when the current through a diode is switched from some forward value, through zero to a reverse value, then back to zero, by applying a reverse switching pulse.

In addition to the Type 291 Diode Switching Time Tester and test fixture, a fast-rise pulse generator, and an oscilloscope is required (see "Pulse Generator and Oscilloscope Requirements"). The basic test system is shown in Fig. 3-3. The oscilloscope is dc coupled, and 50-ohm coaxial cables are used throughout the system. To eliminate possible reflected pulses in the recovery display, the time delay in the cable between the pulse generator and Type 291 should be longer than the recovery time of the diode under test. If the pulse generator has a trigger output, it can be used to externally trigger the oscilloscope.

Vertical display voltage is obtained by diode current passing through the oscilloscope 50-ohm input impedance, thus providing 1 millivolt for each 20 microamps of diode current. The display voltage generated by the diode current can be reduced by connecting an attenuator between

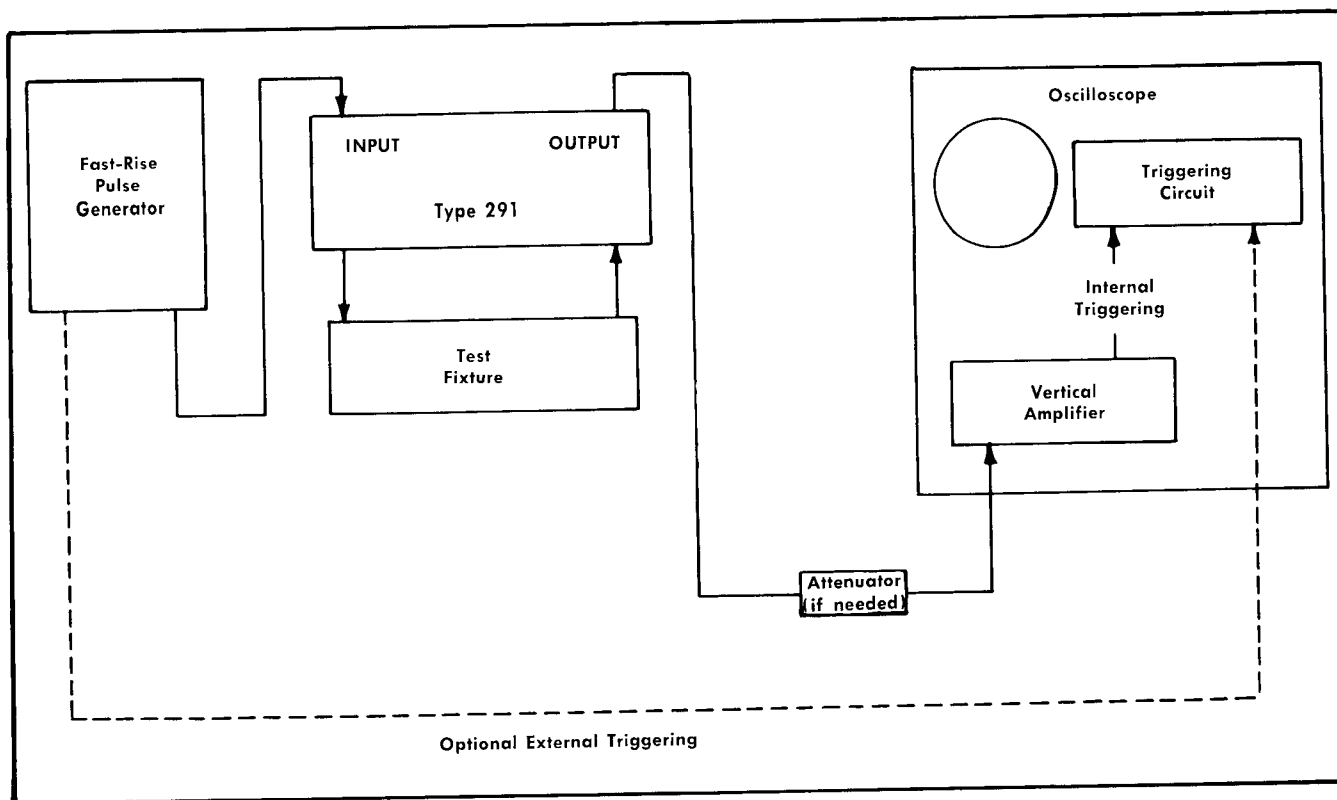

Fig. 3-3. Basic test system.

the Type 291 and the oscilloscope, as shown in Fig. 3-3. However, with an attenuator between the Type 291 and the oscilloscope, the current sensitivity is reduced by the attenuation factor. For example, if a 10X attenuator is used, each millivolt displayed equals 200 microamps of diode current.

Forward-Recovery Switching Characteristics

An oscilloscope display for measuring forward-recovery switching characteristics of a diode can be obtained by the following procedure. Steps 1 through 6 should be used if the forward-switching voltage is known. Steps 4 through 7 should be used if the forward turn-on current (I_{fr}) is known.

1. With the test equipment connected as shown in Fig. 3-3, short across the test fixture by inserting a piece of wire as you would a diode.
2. With the Type 291 POWER/POLARITY switch in the OFF position, turn the pulse generator and oscilloscope on. Set the oscilloscope vertical controls for a voltage-calibrated deflection.
3. Obtain a stable display of the pulse generator output on the crt, and adjust the generator output for the desired forward-switching voltage.
4. With the pulse generator turned off, calibrate the oscilloscope to measure current as described under "Measuring Current With the Oscilloscope", at the end of this section.

5. With the Type 291 POWER/POLARITY switch set to OFF, remove the shorting wire from the test fixture and insert the diode under test. (Place cathode of diode toward oscilloscope input if the output of the pulse generator is positive, or anode toward oscilloscope input if generator pulse is negative.)

6. Turn the pulse generator on, and set the oscilloscope triggering controls for a display similar to that shown in Fig. 3-1. Use this display to measure the forward-recovery switching characteristics of diodes when the forward switching voltage is known. Proceed to step 7 if I_{fr} is known.

7. Set the pulse generator output for the known I_{fr} indication on the display (see Fig. 3-1). Use this display to measure the forward-recovery switching characteristics of diodes when I_{fr} is known.

NOTE

Any number of diodes with the same specifications can be measured by repeating step 6 or 7, whichever applies.

Reverse-Recovery Switching Characteristics

An oscilloscope display for measuring the reverse-recovery switching characteristics of a diode can be obtained by the following procedure. Perform steps 1 through 8 if V_r is known (from which E_{gen} is calculated). Use steps 4 through 9 if the peak reverse current is known.

1. With the test equipment connected as shown in Fig. 3-3, short across the test fixture by inserting a piece of wire as you would a diode.

Operating Instructions — Type 291

2. With the Type 291 POWER POLARITY switch in the OFF position, turn the pulse generator and oscilloscope on. Set the oscilloscope vertical controls for a voltage-calibrated deflection.
3. Obtain a stable display of the pulse-generator output on the crt, and adjust the generator output for the desired E_{gen} .
4. With the pulse generator turned off, calibrate the oscilloscope to measure current as described under "Measuring Current With the Oscilloscope" at the end of this section.
5. With the Type 291 POWER/POLARITY switch set to OFF, obtain a free-running sweep on the oscilloscope, and vertically position the trace to a convenient graticule line. (This establishes a zero current reference, therefore, do not change the vertical position during the rest of this procedure.)
6. With a free-running sweep on the oscilloscope, switch the Type 291 (or external current source, if used) between OFF and NEG.; then adjust the current source controls to give a vertical deflection from the zero current reference that represents the value specified as I_r .
7. Remove the shorting wire from the test fixture, and insert the diode under test (place anode of diode toward oscilloscope input if output of pulse generator is positive, or cathode toward oscilloscope input if generator pulse is negative).
8. Turn the pulse generator on, and set the oscilloscope triggering controls for a display similar to that shown in Fig. 3-2. Use this display to measure the reverse-recovery switching characteristics of diodes whose V_r (then E_{gen}) is known. Proceed to step 9 if the peak reverse current is known.

9. Set the pulse generator output for the known peak reverse current indication on the display. Use this display to measure the reverse-recovery switching characteristics of diodes whose peak reverse current is known.

NOTE

Any number of diodes with the same specifications can be measured by repeating step 8 or 9, whichever applies.

Measuring Current With the Oscilloscope

The oscilloscope vertical deflection can be calibrated to measure current as follows:

1. Connect the test equipment as shown in Fig. 3-3 (the pulse generator is not needed for this procedure, but is necessary when measuring diode switching characteristics), and set the Type 291 CURRENT VARIABLE control to CALIB. and the CURRENT mAMPS control to 10.
2. Short across the test fixture by inserting a piece of wire as you would a diode.
3. Apply power to the Type 291 and obtain a free-running sweep on the oscilloscope.
4. Set the oscilloscope vertical controls for any convenient deflection you want to equal 10 milliamps of diode current as the Type 291 POWER/POLARITY switch is alternated between OFF and NEG. For example, to calibrate the crt for 5 milliamps/division, set the vertical controls for 2 divisions of vertical deflection while alternating between the POWER/POLARITY switch OFF and NEG. positions. Diode current can now be accurately measured as a direct function of crt vertical deflection.

SECTION 4

CIRCUIT DESCRIPTION

Test Circuit

Diode test current is obtained from the Type 291 Power Supply through LOAD-SOURCE jacks J646-J647 when the shorting plug is in place. (See schematic.) C642 isolates the pulse generator from the dc current.

Diode switching pulses from the Pulse Generator are obtained through the INPUT 50 Ω connector. R642 provides a dc return for pulse generators that use a reed switch and charge line to form the pulse (without R642, this type of pulse generator will not produce a pulse). The LC network in the dc current load isolates the power supply dc circuit from the high-frequency pulse path.

Power Supply

The power supply is a series-regulated, full-wave bridge type with a capacitor-input filter.

Power for the circuit is obtained through transformer T601 when the POWER/POLARITY switch is set to NEG. or POS. The output of the filter appears across voltage divider R616, R617, R619, and R622. The output current is stabilized by a reference voltage between the negative return (common lead of C610) and the base of Q624.

A stable reference voltage at the base of Q624 is provided by the double-Zener regulator arrangement of D618 and D619. D618 prevents most of the supply ripple from reaching D619. First-order temperature compensation of D619 is provided by D620. Thus, the voltage drop across D619 and D620 ideally remains constant throughout the normal range of operating temperature.

The reference voltage level at the base of series-regulator transistor Q624 is determined by the setting of R619 when the CURRENT VARIABLE control R622 is set to CALIB. The emitter voltage (compared to the negative return) is established by transistor current through R624, and will follow the base voltage with normal bias characteristics. With the base voltage of Q624 held constant, emitter voltage across R624 also remains constant. The output current is then equal to the setting of the CURRENT mAmps switch.

If the CURRENT VARIABLE control is moved away from the CALIB. position, the base and emitter voltage of Q624 will change toward the negative return voltage. This will decrease the current through R624 from the value indicated for each switch setting.

The direction of current through the test fixture is determined by the setting of the POWER/POLARITY switch.

Regulation of the current to the diode under test is primarily due to the very high collector resistance of Q624. The load resistance changes that can occur are normally a small percentage of the output resistance. Should the load resistance rise quite high (voltage drop across the load also increasing) Zener diode D623 will conduct, permitting Q624 to continue to function.

Line-voltage changes will not affect the output since the base and emitter of Q624 have a common reference voltage at the negative return.

D623 limits the maximum output voltage to about 6.8 volts.

SECTION 5

MAINTENANCE

Removing and Replacing Parts

Removing and replacing procedures for most Type 291 parts are obvious and no detailed instructions are required. However, ceramic strips, switches, and transistors can best be removed by following a definite procedure. Instructions for removing these parts are contained in the following paragraphs.

Access To The Interior

To gain access to the interior of the Type 291, remove the two middle screws on the back of the tester and lift the front panel away from the wrap-around housing.

Soldering Precautions

A silver-bearing solder is used for soldering parts to the ceramic terminal strips to maintain a good solder-to-ceramic bond. When soldering to ceramic strips, use solder containing about 3% silver. If this type of solder is not available locally, it may be purchased directly from Tektronix in one-pound rolls; order by part number 251-514. (Occasional use of ordinary 60-40 solder is permissible on strips already installed, if excessive heat is not applied.)

A wedge-shaped tip on the soldering iron is best for soldering or unsoldering parts on the ceramic strips. This type of tip allows you to apply heat directly to the solder-slot in the strip. Use as little heat as possible and still establish a good solder joint.

To properly solder and unsolder the short-lead components in the Type 291, the following procedure is recommended:

1. Use long-nose pliers for a heat sink. Attach the pliers between the component and the soldered connection.
2. Apply a hot soldering iron to the soldered connection for a short time.
3. Carefully manipulate the component leads to prevent lead or insulation damage.
4. Use only a small amount of solder; just enough to make a good bond.

Replacing Ceramic Terminal Strips

To remove a damaged ceramic terminal strip, first unsolder all connections. Then cut through the yokes and spacers with a pair of diagonal cutters (either at the base of the strip or on the opposite side of the chassis, see Fig. 5-1). Lift the strip away from the chassis and remove the remainder of the yokes and spacers from the chassis holes.

To install a new terminal strip, place the spacers in the chassis holes, insert the yoke pins through the spacers,

and press down on the top of the strip to seat the yokes. If necessary, use a plastic or hard-rubber mallet to seat the yokes firmly. If desired, the extended portion of the yoke pins may be cut off to about an eighth-inch of the lower end of the spacers.

When ordering new ceramic strips, be sure to specify the correct height, number of notches, and spacer size. The yokes are supplied already attached to the strips.

Be sure to follow the procedure under "Soldering Precautions" in this section when soldering components to a terminal strip. Do not use 60-40 solder when replacing strips.

Replacing Switches

Normally, if one wafer is defective in a switch, the entire switch should be replaced. Switches can be ordered from Tektronix, either wired or unwired.

Replacing Transistor

A defective transistor can be removed after its leads are unsoldered and the top of the heat sink is unscrewed with a wrench. To install a new transistor, transfer as much of the silicone grease as possible from the defective transistor to the new one and insert it into the heat sink. Then screw the heat sink top on and tighten with a wrench. Cut the transistor leads to correct length, slip on insulating sleeves, and solder leads to terminal strip.

TROUBLESHOOTING

Introduction

If trouble occurs in the Type 291, the following information will help you troubleshoot the instrument. The information in this section may also be correlated with information from other sections. For example, the Check and

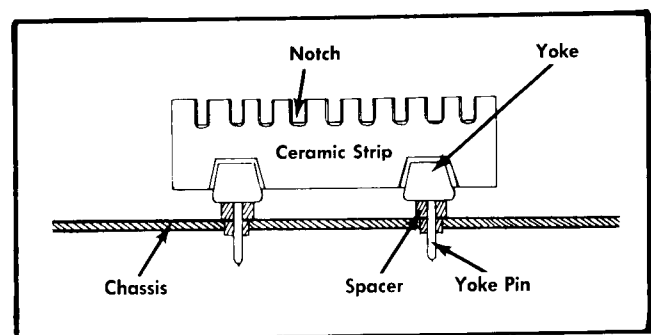

Fig. 5-1. Ceramic strip assembly.

Maintenance — Type 291

Adjustment Procedure (Section 6) may help you determine the source of trouble.

Visual Inspection

Defects such as loose or broken connections, frayed or broken cables, damaged connectors, burned components, and broken terminal strips can generally be detected by a visual inspection. Except for heat-damaged components, the remedy for these defects is obvious. Since heat damage is usually the result of other, less apparent, trouble in the circuit, be sure to locate the source before replacing components.

Checking Semiconductors

Trouble in the Type 291 could be due to semiconductor failure. Semiconductors can be checked by replacing a suspected one with one of the same type or by using a tester.

Semiconductors can also be checked with an ohmmeter if no other method is available. However, resistance readings of semiconductors of the same type may vary. Therefore, resistance readings are valid only when checking for front-to-back resistance, opens, and shorts. Avoid using the RX1 scale of the ohmmeter because the high current of this scale can damage a good semiconductor.

SECTION 6

CHECK AND ADJUSTMENT

General

The Type 291 has only one internal adjustment . . . R619 in the power-supply circuit. Since the power supply is a stable circuit, this adjustment should only require checking about once every six months, or after each 500 hours of operation. However, if troubles develop in the Type 291, the information in this section may help you determine the cause.

Two procedures are provided. The first is for a general performance check, and assumes that the current-setting resistors (R624 A through G) change the same percentage with age. The second is for a complete check and adjustment of all power-supply characteristics.

PROCEDURE 1

Equipment Required

1. A variable line-voltage autotransformer, rated at 6 watts or more.
2. A dc voltmeter with a sensitivity of at least 20,000 Ω /volt with a corrected reading of at least 1% at 0.5 volt, and 3% up to 50 volts.
3. A 50 Ω precision resistor, 0.5 to 1%, 1 watt. (Do not use the Tektronix 50 Ω Termination, part no. 017-047.)
4. A test oscilloscope with a calibrated vertical deflection factor of 50 mv/div.

Procedure

1. Insert the shorting plug into J646 and J647.
2. Connect the precision 50 Ω resistor between the center and outer conductors of J649, and connect the voltmeter across the resistor (set to measure 0.5 volt).
3. Connect the autotransformer between the Type 291 power plug and the power line. Adjust the autotransformer for 117 volts output (or 234 volts if required).
4. Set the CURRENT mAMPS switch to 10 and turn on the Type 291.
5. Remove the CURRENT mAMPS control knob. Insert a narrow screwdriver through the center of the CURRENT mAMPS control shaft and adjust R619 for a 0.5-volt indication on the voltmeter.
6. Remove the voltmeter.
7. Set the CURRENT mAMPS switch to 100.
8. Connect the test oscilloscope (without an attenuator probe) across the 50 Ω resistor. Set the oscilloscope sweep

rate to 5 msec/div, internally triggered on the line frequency. The power supply ripple should not exceed 10 mv peak-to-peak, while changing the autotransformer from 105 to 125 volts. If excessive ripple is present, open the Type 291 case and measure voltages in the power supply with the 20,000 Ω /V meter. Typical voltages are included on the schematic. Be sure to note the conditions under which the voltages were obtained.

PROCEDURE 2

Equipment Required

1. A variable line-voltage autotransformer, rated at 6 watts or more.
2. A dc voltmeter with a sensitivity of at least 20,000 Ω /V, with 3% accuracy up to 50 volts.
3. A precision dc voltmeter, preferably an infinite impedance type, with 0.2% accuracy at the voltage values listed in Table 6-1.
4. A 50 Ω precision resistor, 0.2%, 1 watt.
5. A test oscilloscope with a calibrated vertical sensitivity of 1 mv/div (or more sensitive if available).

Procedure

1. Insert the shorting plug into J646 and J647.
2. Connect the 50 Ω resistor between the center and outer conductors of J649, and connect the precision dc voltmeter across the resistor.
3. Connect the autotransformer between the Type 291 power plug and the power line. Adjust the autotransformer for 117 volts output (or 234 volts if required).
4. Set the CURRENT mAMPS switch to 10 and turn on the Type 291.
5. Remove the CURRENT mAMPS knob. Insert a narrow screwdriver through the center of the CURRENT mAMPS shaft, and adjust R619 for 0.5 volt.
6. Replace the CURRENT mAMPS knob. Vary the autotransformer from 105 to 125 volts for each CURRENT mAMPS switch setting listed in Table 6-1, and check for the proper output voltage. If any are out of tolerance, try adjusting R619 to place all ranges within proper tolerance. If this fails, replace the resistor associated with the out-of-tolerance range, and recheck.
7. Remove the voltmeter and connect the test oscilloscope to the precision resistor, without an attenuator probe. Set

Check and Adjustment — Type 291

the sweep rate to 5 msec/div, internally triggered on the line frequency.

8. Using Table 6-1, check the ripple at each position of the CURRENT mAMPS switch when varying the auto-transformer output from 105 to 125 volts. If excessive ripple is present, open the Type 291 case, and measure voltages in the power supply with the 20,000 Ω /V meter. Typical voltages are included on the schematic. Be sure to note the conditions under which the voltages are obtained.

9. Remove the resistor and connections from J649. Set the CURRENT mAMPS switch to 100. The voltage between the center and outer conductors of J649 should be 6.8 volts $\pm 10\%$. Reverse the POWER/POLARITY switch positions; the voltage polarity should reverse.

TABLE 6-1

CURRENT mAMPS Switch Setting	Output Voltage	Nominal Peak-To-Peak Ripple
1	.05 v \pm 1 mv	0.5 mv
2	0.1 v \pm 2 mv	0.5 mv
5	0.25 v \pm 5 mv	0.5 mv
10	0.5 v \pm 10 mv	0.5 mv
20	1 v \pm 20 mv	0.5 mv
50	2.5 v \pm 50 mv	2.0 mv
100	5 v \pm 150 mv	10 mv

SECTION 7

PARTS LIST AND SCHEMATICS

PARTS ORDERING INFORMATION

Replacement parts are available from or through your local Tektronix Field Office.



Changes to Tektronix instruments are sometimes made to accommodate improved components as they become available, and to give you the benefit of the latest circuit improvements developed in our engineering department. It is therefore important, when ordering parts, to include the following information in your order: Part number including any suffix, instrument type, serial number, and modification number if applicable.

If a part you have ordered has been replaced with a new or improved part, your local Tektronix Field Office will contact you concerning any change in part number.

ABBREVIATIONS AND SYMBOLS

a or amp	amperes	mm	millimeter
BHS	binding head steel	meg or M	megohms or mega (10 ⁶)
C	carbon	met.	metal
cer	ceramic	μ	micro, or 10 ⁻⁶
cm	centimeter	n	nano, or 10 ⁻⁹
comp	composition	Ω	ohm
cps	cycles per second	OD	outside diameter
crt	cathode-ray tube	OHS	oval head steel
CSK	counter sunk	p	pico, or 10 ⁻¹²
dia	diameter	PHS	pan head steel
div	division	piv	peak inverse voltage
EMC	electrolytic, metal cased	plstc	plastic
EMT	electrolytic, metal tubular	PMC	paper, metal cased
ext	external	poly	polystyrene
f	farad	Prec	precision
F & I	focus and intensity	PT	paper tubular
FHS	flat head steel	PTM	paper or plastic, tubular, molded
Fil HS	fillister head steel	RHS	round head steel
g or G	giga, or 10 ⁹	rms	root mean square
Ge	germanium	sec	second
GMV	guaranteed minimum value	Si	silicon
h	henry	S/N	serial number
hex	hexagonal	t or T	tera, or 10 ¹²
HHS	hex head steel	TD	toroid
HSS	hex socket steel	THS	truss head steel
HV	high voltage	tub.	tubular
ID	inside diameter	v or V	volt
incd	incandescent	Var	variable
int	internal	w	watt
k or K	kilohms or kilo (10 ³)	w/	with
kc	kilocycle	w/o	without
m	milli, or 10 ⁻³	WW	wire-wound
mc	megacycle		

SPECIAL NOTES AND SYMBOLS

X000	Part first added at this serial number.
000X	Part removed after this serial number.
*000-000	Asterisk preceding Tektronix Part Number indicates manufactured by or for Tektronix, or reworked or checked components.
Use 000-000	Part number indicated is direct replacement.
	Internal screwdriver adjustment.
	Front-panel adjustment or connector.

EXPLODED VIEW

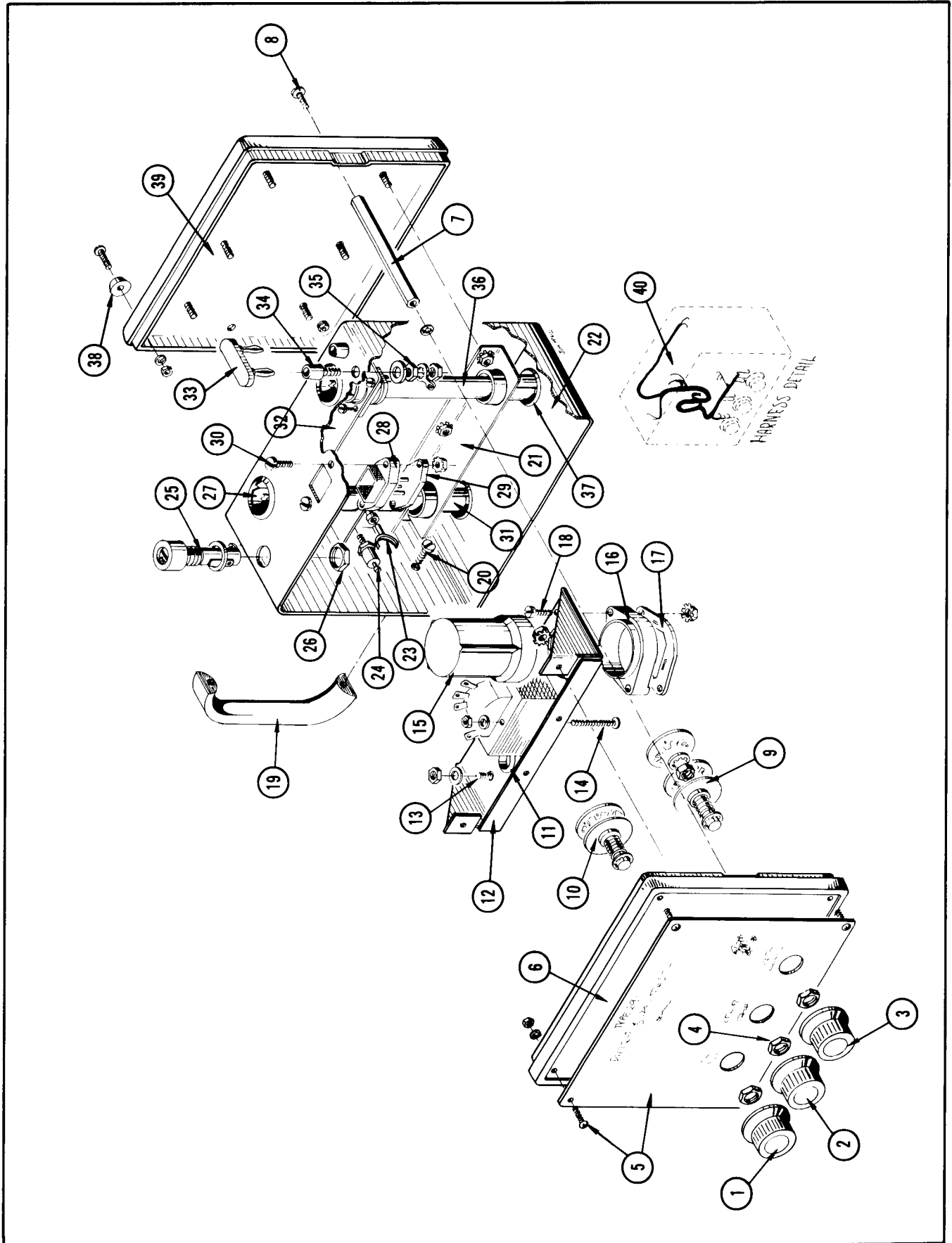

Exploded View

REF. NO.	PART NO.	SERIAL NO.		QTY.	DESCRIPTION
		EFF.	DISC.		
1	366-145			1	KNOB, POWER/POLARITY, charcoal
2	366-455			1	KNOB, CURRENT VARIABLE, charcoal
3	366-145			1	KNOB, CURRENT mAMPS, charcoal
4	210-413			1	Pot Mounting Hardware: NUT, hex, brass, $\frac{3}{8}$ -32 x $\frac{1}{2}$ in.
5	333-732			1	PANEL, front Mounting Hardware: (not included)
	210-004			4	LOCKWASHER, steel, internal #4
	210-406			4	NUT, hex, brass 4-40 x $\frac{3}{16}$ in.
	211-071			4	SCREW, 4-40 x $\frac{3}{8}$ in. PHS, phillips
6	200-435			1	COVER, box, top, large, alum. 6.031 x 7.031 in. Mounting Hardware: (not included)
7	385-167			2	ROD, spacer, $\frac{1}{4}$ in. alum. hex rod, 3.535 in. long
	210-006			2	LOCKWASHER, steel, internal #6
8	211-507			2	SCREW, 6-32 x $\frac{5}{16}$ in. BHS
9	260-485			1	SWITCH, CURRENT m AMP, unwired Mounting Hardware: (not included)
	210-012			1	LOCKWASHER, steel, internal $\frac{3}{8}$ x $\frac{1}{2}$ in.
	210-413			1	NUT, hex, brass, $\frac{3}{8}$ -32 x $\frac{1}{2}$ in.
10	260-484			1	SWITCH, POWER/POLARITY, unwired Mounting Hardware: (not included)
	210-012			1	LOCKWASHER, steel, internal $\frac{3}{8}$ x $\frac{1}{2}$ in.
	210-413			1	NUT, hex, brass, $\frac{3}{8}$ -32 x $\frac{1}{2}$ in.
11	348-005			1	GROMMET, rubber, $\frac{1}{2}$ in.
12	441-462			1	CHASSIS Mounting Hardware: (not included)
	210-202			1	LUG, solder, SE6, with 2 wire holes
	210-407			1	NUT, hex, brass, 6-32 x $\frac{5}{16}$ in.
	210-457			3	NUT, Keps, steel, 6-32 x $\frac{5}{16}$ in.
13	210-010			1	Transistor Mounting Hardware: LOCKWASHER, steel, internal #10
	210-410			1	NUT, hex, brass, 10-32 x $\frac{5}{16}$ in.
	214-289			1	SINK, heat, stud mount
14	210-406			2	Transformer Mounting Hardware: NUT, hex, brass, 4-40 x $\frac{3}{16}$ in.
	211-021			2	SCREW, 4-40 x $1\frac{1}{4}$ in. RHS
15	200-260			1	COVER, capacitor, polyethylene, $2\frac{1}{32}$ x 1.365 in. dia.
	200-360			1	COVER, capacitor, black plastic, $2\frac{1}{16}$ x 1.365 in. dia. (optional replacement)
16	432-044			1	BASE, capacitor, mounting, large, delrin
17	386-254			1	PLATE, fiber, large Mounting Hardware: (not included)
18	211-532			2	SCREW, 6-32 x $\frac{3}{4}$ in. Fil. HS
	210-457			2	NUT, keps, steel, 6-32 x $\frac{5}{16}$ in.
19	367-007			1	HANDLE, drawer Mounting Hardware: (not included)
20	212-001			2	SCREW, 8-32 x $\frac{1}{4}$ in. BHS
21	406-874			1	BRACKET, ground connector (front) Mounting Hardware: (not included)
	210-458			3	NUT, keps, steel, 8-32 x $1\frac{1}{32}$ in.
22	380-043			1	HOUSING, wrap around, steel, 6.875 x 5.875 x $2\frac{1}{4}$ in.

Parts List — Type 291

REF. NO.	PART NO.	SERIAL NO.		QTY.	DESCRIPTION
		EFF.	DISC.		
23	426-121			1	MOUNT, toroid, nylon, $1\frac{5}{32} \times \frac{1}{8} \times \frac{9}{64}$ in.
24	129-006			1	POST, connecting, insulated
25	352-007			1	HOLDER, fuse
	210-873			1	WASHER, rubber, $\frac{1}{2}$ ID x $1\frac{1}{16}$ OD x $\frac{3}{64}$ in.
26				1	NUT, (included with 352-007)
27	132-001			2	NUT, coupling
	132-002			2	SLEEVE, conductor, outer
	132-007			2	RING, snap
	132-121			2	NUT, retaining
	132-028			2	INSULATOR
	132-029			2	CONDUCTOR, inner
	132-040			2	ADAPTER, 1.050 x 1.050 in.
	211-065			8	SCREW, 4-40 x $\frac{3}{16}$ in. PHS
28	380-047			1	HOUSING, 3 pin socket
29	136-144			1	SOCKET, 3 pin
					Mounting Hardware: (not included)
30	211-540			2	SCREW, 6-32 x $\frac{1}{2}$ in. THS, Phillips
	210-457			2	NUT, keps, steel, 6-32 x $\frac{5}{16}$ in.
31	166-297			1	TUBE, chassis assembly
	214-290			1	SPRING, rod conductor, stainless steel wire, .145 OD x $\frac{3}{8}$ lg.
	361-043			1	SPACER, 50 Ω , clear polypropylene, .566 in. dia.
	384-607			1	ROD, center conductor, $\frac{1}{4}$ in. brass rod x 1.258 long
	384-610			1	ROD, contact, $\frac{5}{32}$ in brass rod x $\frac{7}{16}$ long
32	406-873			1	BRACKET, ground connector (rear)
					Mounting Hardware: (not included)
	210-228			1	LUG, solder, SE10, long
	210-458			2	NUT, keps, steel, 8-32 x $1\frac{1}{32}$ in.
33	134-012			1	PLUG, banana, male, twin
34	136-140			2	SOCKET, banana jack, with charcoal cap
					Mounting Hardware for each: (not included)
35	210-223			1	LUG, solder, $\frac{1}{4}$ in. hole
	210-465			1	NUT, hex, brass, $\frac{1}{4}$ -32 x $\frac{3}{8}$ x $\frac{3}{32}$ in.
	210-819			1	WASHER, Bakelite, rect. $\frac{1}{4}$ in. x $\frac{1}{2}$ in x .046 in.
36	166-296			1	TUBE, air passage (right)
	384-608			1	ROD, center conductor, $\frac{1}{4}$ in brass rod x .750 long
	384-609			1	ROD, center conductor, $\frac{1}{4}$ in. brass rod x 3.925 long
37	132-001			2	NUT, coupling
	132-002			2	SLEEVE, conductor, outer
	132-007			2	RING, snap
	132-028			2	INSULATOR
	132-029			2	CONDUCTOR, inner
	200-371			2	COVER, ground nut, gray vinyl, .840 dia. x .375 in. high
38	348-037			4	FOOT, rubber, black, $\frac{1}{4}$ dia. x $\frac{3}{16}$ in. high
					Mounting Hardware for each: (not included)
	210-004			1	LOCKWASHER, steel, internal #4
	210-406			1	NUT, hex, brass, 4-40 x $\frac{3}{16}$ in.
	211-011			1	SCREW, 4-40 x $\frac{5}{16}$ in BHS
39	200-436			1	COVER, box, bottom, large, alum. 6.031 x 7.031 in.
40	179-695			1	CABLE, harness, chassis

Standard Accessories

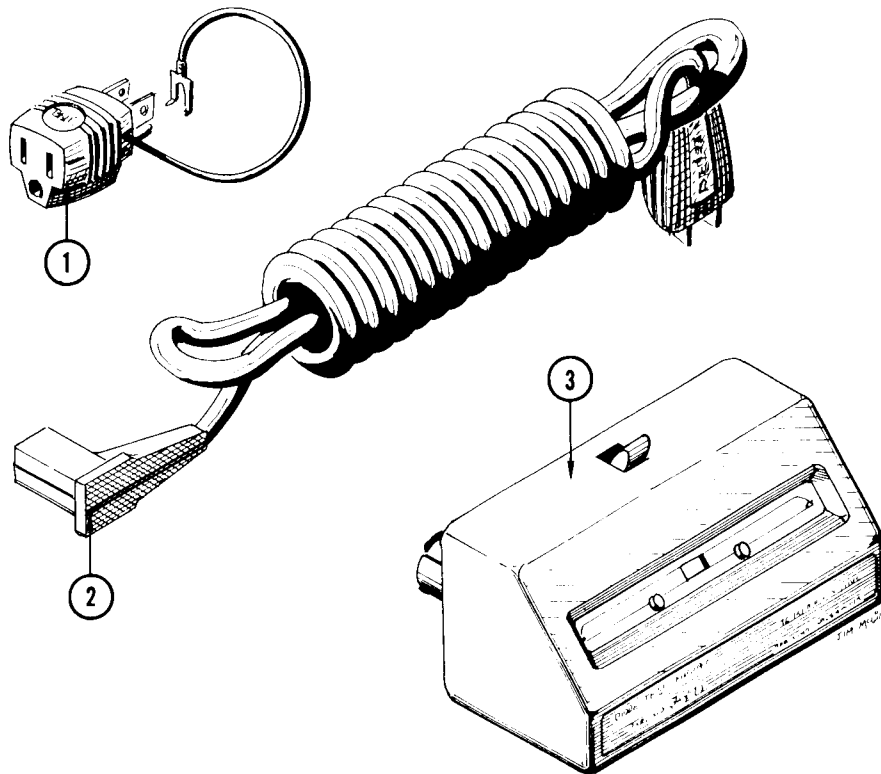

REF. NO.	PART NO	SERIAL NO.		QTY.	DESCRIPTION
		EFF.	DISC.		
1	103-013			1	ADAPTER, power cord, 3 to 2 wire
2	161-015			1	CORD, power, 20 gauge, 8 ft.
3	017-072			1	FIXTURE, diode test (Optional accessory)

ELECTRICAL PARTS LIST

Values are fixed unless marked Variable.

Ckt. No.	Tektronix Part No.	Description	S/N Range
----------	--------------------	-------------	-----------

Capacitors

Tolerance of all electrolytic capacitors are as follows (with exceptions):

3 V — 50 V = —10%, +250%
 51 V — 350 V = —10%, +100%
 351 V — 450 V = —10%, +50%

C601	285-623	.47 μ f	PTM	100 v	
C610A, B, C, D	290-070	4 x 75 μ f	EMC	150 v	
C624	281-524	150 pf	Cer.	500 v	
C642	283-064	.05 μ f	Disc Type	50 v	
C645	283-563	.001 μ f	Mica	500 v	10%

Diodes

D610A, B, C, D	152-066	Silicon	1N3194 (or equivalent)		
D618	152-059	Zener	12.6 v	1 w	5%
D619	152-105	Zener	1N2620	9.3 v	
D620	152-058	Stabistor	SG22		
D623	152-104	Zener	6.8 v	1 w	10%

Fuses

F601	159-048	1/10 Amp	3AG	Slo-Blo	234 v oper.
	159-051	1/16	3AG	Slo-Blo	117 v oper.

Inductors

L643	276-532	Ferrite Beads			
L645	108-205	1 mh			

Resistors

Resistors are fixed, composition, $\pm 10\%$ unless otherwise indicated.

R608	307-033	6.8 Ω	1/2 w		
R610	307-049	3.9 Ω	1/2 w		
R612	307-049	3.9 Ω	1/2 w		
R614	307-049	3.9 Ω	1/2 w		
R616	308-243	240 Ω	3 w		WW 5%
R617	301-910	91 Ω	1/2 w		5%
R619	311-258	100 Ω		Var.	CAL.
R622	311-005	500 Ω		Var.	CURRENT VARIABLE
R624A	308-239	84 Ω	3 w		WW 1%
R624B	309-360	170 Ω	1/2 w		Prec. 1%

Parts List — Type 291

Resistors (Cont'd)

Ckt. No.	Tektronix Part No.		Description		S/N Range
R624C	309-425	422 Ω	$\frac{1}{2}$ w	Prec.	1%
R624D	309-315	845 Ω	$\frac{1}{2}$ w	Prec.	1%
R624E	319-061	1.69 k	$\frac{1}{4}$ w	Prec.	1%
R624F	319-059	4.22 k	$\frac{1}{4}$ w	Prec.	1%
R624G	319-062	8.45 k	$\frac{1}{4}$ w	Prec.	1%
R642	318-073	5.88 k	$\frac{1}{8}$ w	Prec.	1%
R645	302-102	1 k	$\frac{1}{2}$ w		

Switches

SW620	260-484	Rotary	POLARITY
SW624	260-485	Rotary	CURRENT SELECTOR

Transformers

T601	*120-294	L. V. Power
L644	*120-295	Toroid 9T TD82

Transistors

Q624	151-103	Planar Silicon
------	---------	----------------

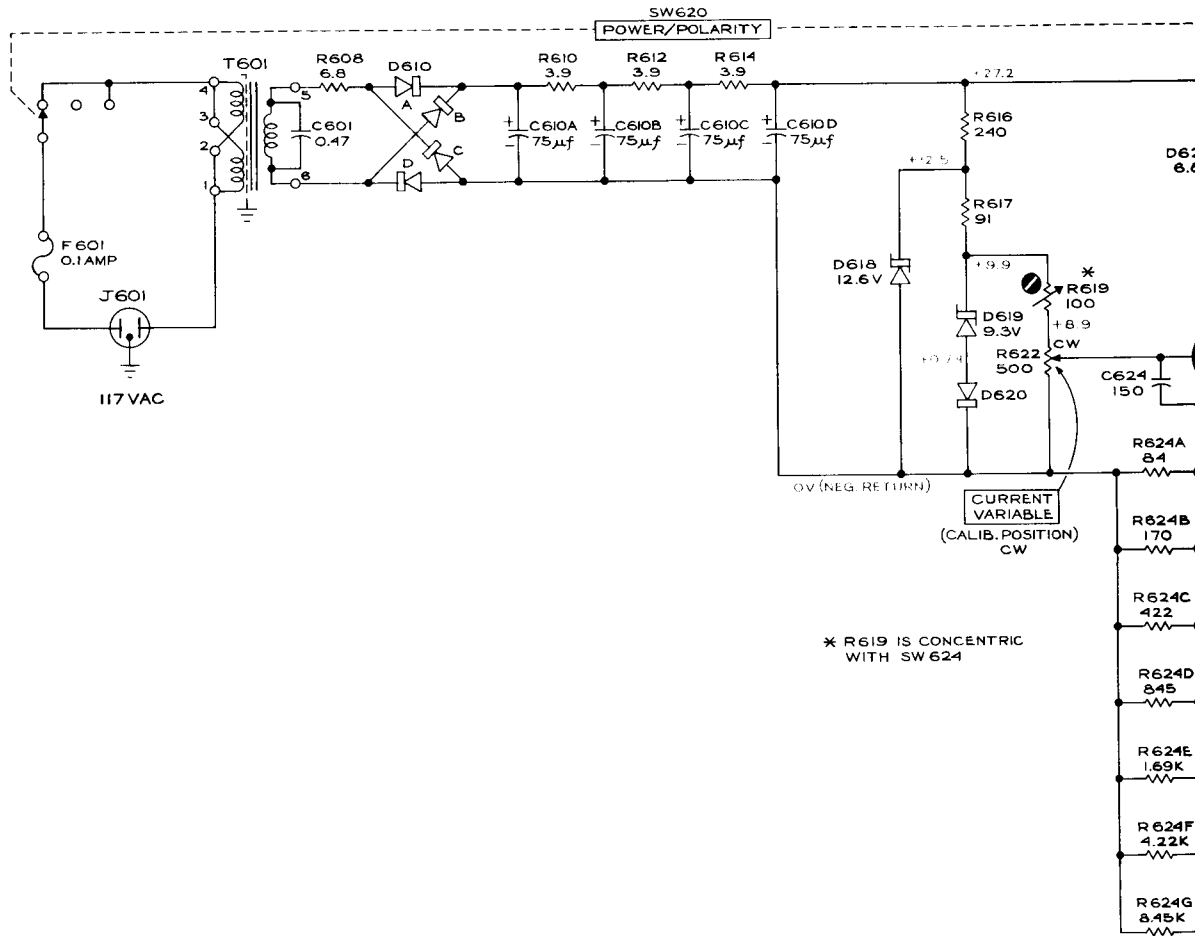
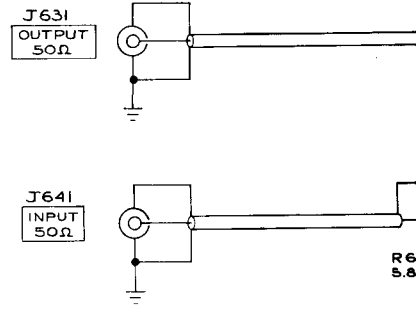

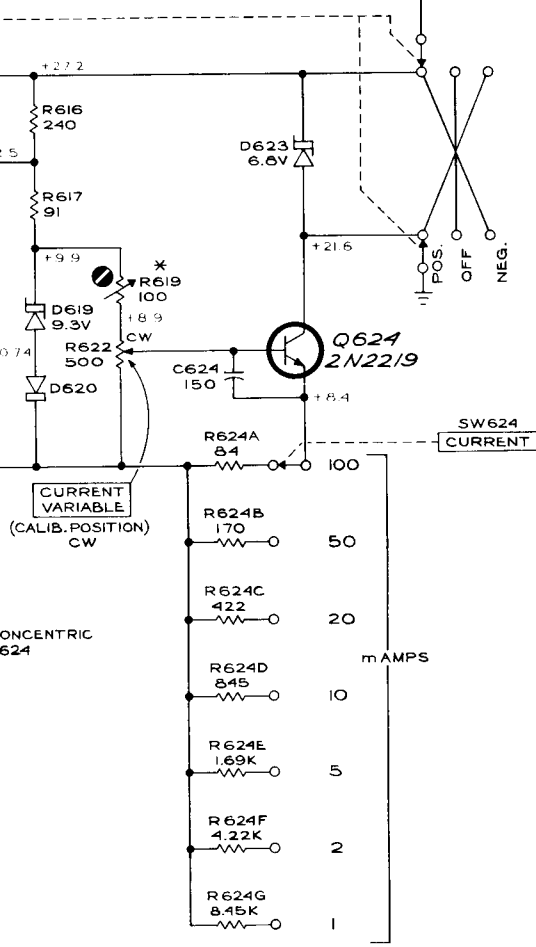
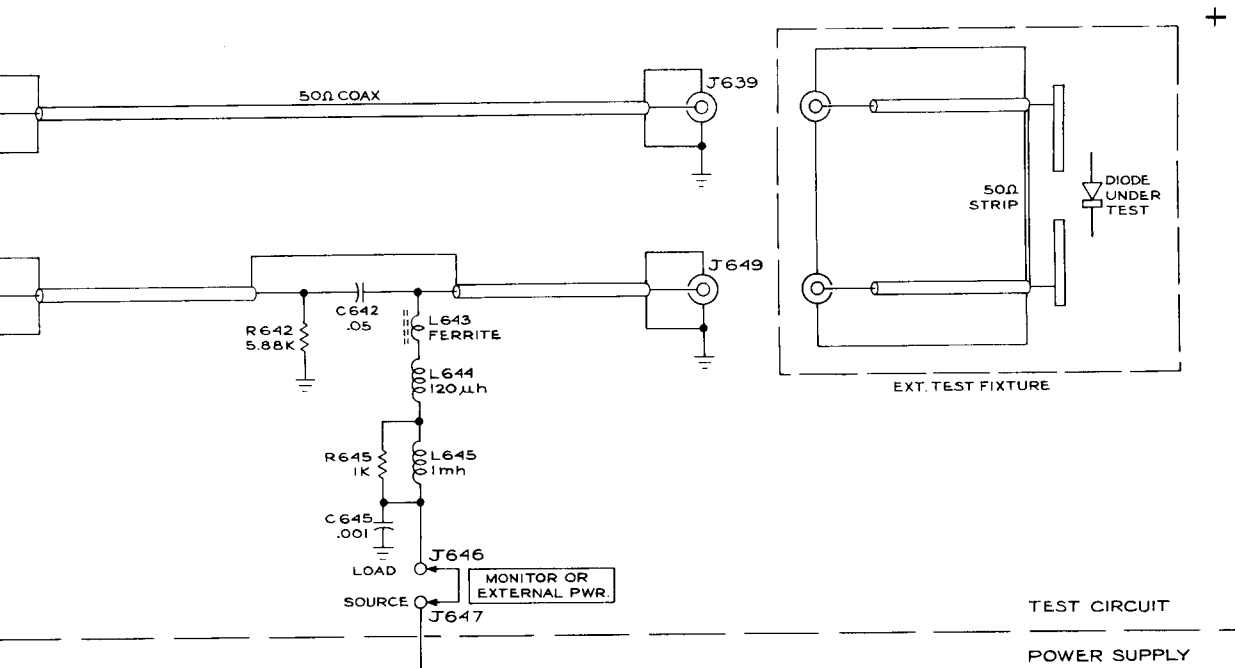

VOLTAGE READINGS WERE OBTAINED UNDER FOLLOWING CONDITIONS:

INPUT	117VAC
J649	INSERT 50Ω ATEN
J646, J647	INTERCONNECTED
CURRENT (mAMPS)	100
CURRENT VARIABLE	CALIB.
POWER (POLARITY)	POS.

IMPORTANT:
 ALL VOLTAGE READINGS WERE OBTAINED WITH A CENTRAL-VOLVOM. ALL READINGS ARE IN VOLTS, AND MUST BE MULTIPLIED BY 10 TO OBTAIN COMMON LEAD VALUE IN AMPLITUDE MEASUREMENTS, AS SHOWN. ALL READINGS ARE NOT ABSOLUTE; THEY MAY VARY BETWEEN 1% TO 2% DUE TO TOLERANCES AS WELL AS WITHIN THE INSTRUMENT DUE TO NORMAL MANUFACTURING TOLERANCES, AND TO VARIATION OF CHARACTERISTICS.

MANUAL CHANGE INFORMATION

At Tektronix, we continually strive to keep up with latest electronic developments by adding circuit and component improvements to our instruments as soon as they are developed and tested.

Sometimes, due to printing and shipping requirements, we can't get these changes immediately into printed manuals. Hence, your manual may contain new change information on following pages. If it does not, your manual is correct as printed.